

Osaki

INSTRUCTION MANUAL
INSTRUCTION MANUAL
INSTRUCTION MANUAL

Marquis

PRO SERIES



Charming Health

Principles of Massage

The Osaki OS Pro Marquis massage chair integrates a variety of effective and well known massage technics, providing one of the most life-like experiences. Bring the luxury and experience of your own person massage therapist into your home for fractions of the cost.

TABLE OF CONTENTS

Before Use

Safety Cautions ----- 1
 Product Features ----- 2
 Product Structures ----- 2-3

Operating Instructions

Operating Instructions of Massage Chair (Automatic operation) ----- 3
 Operating Instructions of Remote Control ----- 4-7
 Notices After Using ----- 8-9

Installations

Installation for Backrest ----- 10-11
 Installation for Seat Cushion -----12
 Installation for Armrest ----- 12-13
 Installation for Back Cushion and Head Cushion -----14
 Preparations before Use -----15

Maintenance and Repair

Maintenance ----- 16
 Maintenance and Storage -----16
 Troubleshooting -----17
 Specifications -----17

Principles of Massage Chair

Diagram of Spine -----18
 Diagram of Acupuncture Points in Sole ----- 18
 Principles of Massage -----19

Safety Cautions

- Before using the equipment, please read the "Safety Cautions" thoroughly for correct use.
- The following precautions help you safely and correctly use the equipment, and avoiding possible damage to property or injury to persons using chair and others.
- The precaution items are categorized into "Warning" items and "Caution" items according to the degree of danger if they are not abided by.
- After reading, please keep this manual in a place that is easily accessible for future reading.
- This chair is not intended for use by person (including children) with reduced physical, sensory or mental capabilities or lack of experience and knowledge, unless they have been given supervision or instruction concerning use of the chair by a person responsible for their safety. Children should be supervised to ensure that they do not play with the chair.

⚠ Warning

When using the backrest adjusting function	Please make sure if there is any person (especially an infant or a child), pet, or obstacle such as furniture behind the chair. Avoid any accident of people injury, furniture or chair damages.
Do not use power supply with incorrect voltage	The use of incorrect voltage may cause accident such as electric shock or fire.
When there is failure of massage chair	Please pull out the power plug from the socket immediately and call the dealer for inquiry.
When there is power outage	Please turn off the power switch and pull out the power plug.
When not in use	Please turn off the power switch and pull out the power plug from the socket.
When the power cable or plug is damaged	To avoid any danger, they should be replaced by professional technicians from the manufacturer or its service agency or by other qualified personnel.
The chair should be placed in a flat floor.	Placing the equipment in an unsteady place may cause noise
Do not sit on the armrest or the backrest	Otherwise, the equipment may be turned over, causing injury and damage of the equipment.
When the surface materials is found be torn	Please stop using the equipment and notify the dealer of the same immediately, otherwise an accident may occur.

⚠ In case of the followings, please use the equipment following doctor's advice.

● Patients currently receiving medical treatment, especially those feeling unwell in body.
● Patients with abnormal backbone
● Patients with malignant tumor.
● Patients with any acute diseases.
● People with osteoporosis.
● Women in pregnancy or during menstruation.
● Aged people.
● People with heart diseases (patients with angina or myocardial infarction or equipped with heart pacemakers).
● Patients with high fever.
● People with weak body.
● People with sensation disabilities.

⚠ Caution

This chair must be grounded.	May result in damages to the chair or electric shock.
No adaptor or transformer device should be used with this chair.	Do not use external adaptors or transformers which may cause serious damage to the chair and person bodily injury.
Do not use gasoline or thinner to clean the equipment.	May result in leather aging and discoloration may be caused, or a fire accident caused.
Do not sit on the armrest or backrest.	May result in injury or equipment damages.
Do not move the chair by rolling the casters on wooden floor or carpet.	May result in floor damages .
Do not use the chair immediately after meal.	You may feel indisposed.
Do not move the chair when someone is sitting on it.	May cause you to feel nauseous
Do not allow two or more people sitting on the chair at the same time.	May result in injury or equipment damages.
Do not use the equipment without wearing any clothes.	The skin is directly rubbed by surface of the chair, causing skin pain.
Do not wear any ornament on head when using the equipment.	May result in injury.
Do not bump the armrest with hard or sharp things.	The appearance may be damaged.
Do not operate under blanket or pillow.	Excessive heating can occur and cause fire, electric shock or injury to persons.
Do not spill water or liquids on the chair.	May result in electric shock, short circuit or combustion.
Do not use outdoors.	May result in equipment damages.

Troubleshooting

Problems	How to Check	How to Solve
Noise during operation	These are the normal sound of motor. No need to check.	No need to do anything.
The noise is getting louder during massage	Check whether the massage chair has been operating continuously for over 4hours.	Switch off the massage chair and allow at least an hour rest.
The massage chair surface is hot	Check whether the massage chair has been operating continuously for over 4hours.	Switch off the massage chair and allow at least an hour rest.
The massage chair sometime pauses	Check whether the power plug on the socket is loose.	Try the unit again or check the power supply.
The massage roller are stayed at the waist when startup the power.	The ON/OFF button is not pressed after the unit is powered on.	Press the ON/OFF button and then select any of the function buttons.
	The timer function has shut off the massage function.	Press the ON/OFF button or select any of the function buttons.
	The chair has just been powered on and the massage roller is not in the highest position.	Please press any of the auto function buttons, and then the massage roller will reach shoulder automatically.
	The power cord is not connected.	Connect the power plug and switch on the unit.
When the massage chair is not functioning properly from the remote control, you should switch it off for a while and switch on again. If the problem persists after trying the solutions given in this guide, please contact the local sales dept.		

⚠ Caution

- During operation, the following noises are a normal part of the chair's operation and do not affect its performance in any way.
 - Noises during tapping
 - Sound of the rollers rubbing against the seat cover during kneading.
 - Sound of raising and lowering the roller.
 - Sound of the air massage cushion.
 - Sound of air pump, air discharge.
 - Sound of raising and lowering the reclining seat back and footrest.

Specifications

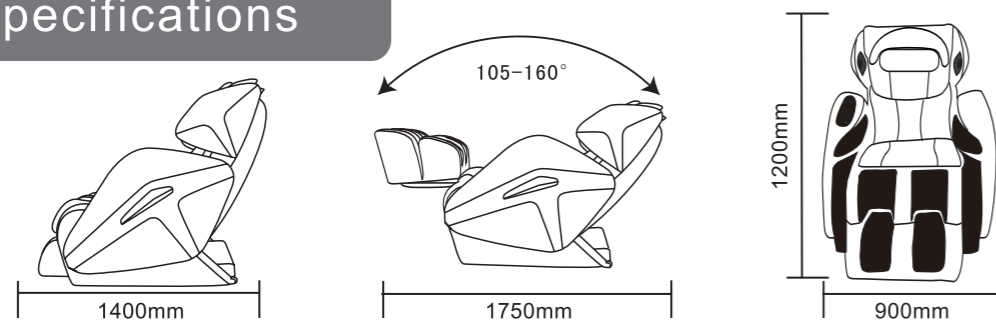

Model	Osaki OS-Pro Mavqnis
Function	6 auto functions, sync movement armrests, lengthened hand massage, lengthened massage tracking full body air massage, super slow massage function, one button start-up function, zero space concept
Tracking	800mm
Reclining angle	105-160° stepless adjustment
Power supply	AC □220V~50Hz □120V-60Hz
Consumption	150W
Timer setting	15-minute automatic timed shutdown
Safety device	Devices that have protection of overheating, over-current, over-voltage, protection against abnormal program, foot rest anti-jam prevention and function of auto switch-off.
NW/GW of backrest carton	120 lbs./141 lbs
NW/GW of main body carton	230 lbs./260 lbs
Dimensions of backrest carton	48 1/2" x 30 1/2" x 27 3/4"
Dimensions of main body carton	54 3/4" x 33 1/4" x 21 1/2"
Outer Covering	PU massage chair leather

Standards applied: GB-4706.10-2008

*The specifications are subject to changes without further notice.

Product Features

- Easily assembly of armrest
The armrest can be assembled easily and safely, very convenient.
- Patented safety design of footrest
The lifting of footrest is not restricted by the movement of motor extension, and it can be automatically adjusted as per the heights of people.
- 3-D feeling of whole-body air massage
Adopting advanced patented air system, which provides ample air pressure and continuous airflow to make you enjoy perfect massage.
- Zero space design
Unique zero space concept can save much room space, only need 2-fingers away from wall.
- Safe motor equipment
European safety design motor with a low voltage of 24V, adopted to reduce noise and create a comfortable massage.
- Six super powerful auto programs allowing perfect massage
Six convenient and automatic massage programs are specially designed to enable you to enjoy the massage like conducted by professional massage therapist.
- Various massage techniques
The chair provides various techniques including Shiatsu, massaging, kneading, tapping, air pressure and etc. and it can carry out different massages by combining these basic techniques.
- Slide-to-store remote control
Perfect designed of the slide-to-store remote control makes the operations more convenient.
- The second generation auto back detection
Infrared location can precisely detect your body shape and automatically scan your spine length to achieve an optimum massage position.

Product Structures

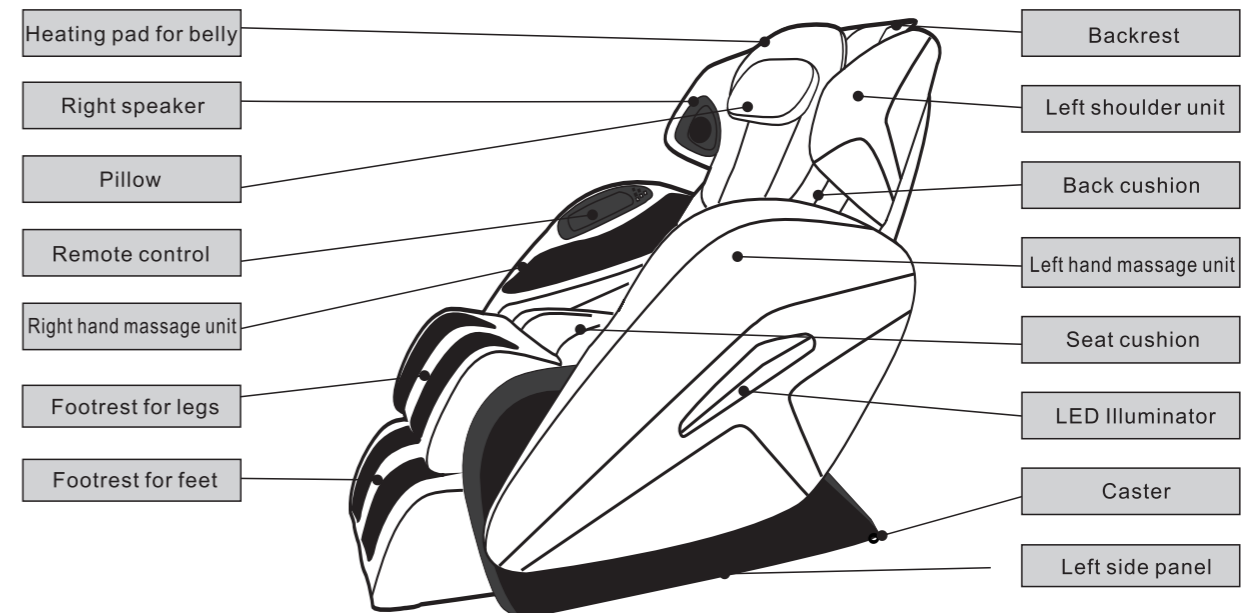

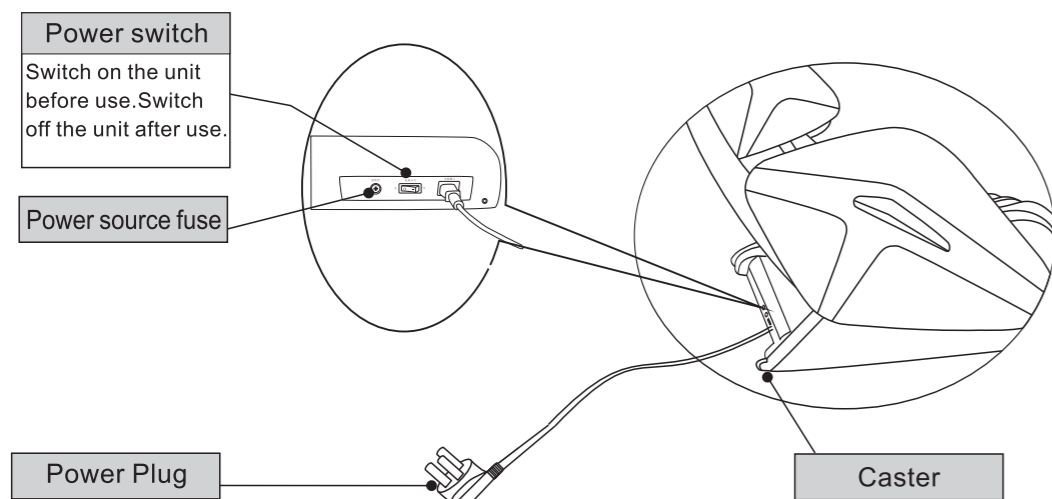

ⓘ Caution

- Before plugging the power cord into the wall outlet, make sure that the main Power switch is set to OFF.
- The Power plug must be plugged properly to an outlet, otherwise, it may result in electric shock or combustion.
- Do not use the same power outlet with other electric appliances.
- Do not use with any type of transformer device.

Operating Instructions of Massage Chair (Automatic Operation)

1. Connect the power plug to a wall socket.

2 Turn on the power switch. (as per picture)
(The power switch is behind the backrest.)

Turn on the power switch, the LED Illuminators will light up and the power button of remote control will turn red.

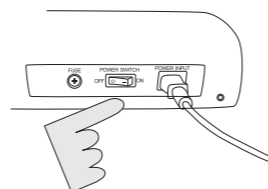

3. Turns the remote control "ON/OFF" key (as per picture)

After pressing the "ON/OFF" key, it turns blue, the seat will vibrate, and auto adjust the best position, then scan your body and enter the zero gravity program.
※You can press any other auto massage program to change the mode at any time. Press "ON/OFF" key again, it turns red and turns off the appliance.

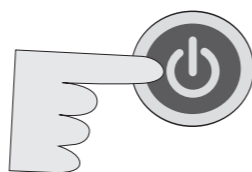

Maintenance

⚠ Warning

For maintenance or cleaning, please turn off the power switch first, then unplug the power plug from the socket.

Methods and Steps for the maintenance of the massage chair

Methods:

Please use soft dry cloth to wipe the surface of the equipment (do not use benzoline, alcohol or dilutor and let them drop onto the chair surface). Otherwise, the chair surface may be deformed and leather may deteriorate. Soak a piece of soft cloth in warm water and cleanser. Use the cloth to flap the chair surface. Lastly, use dry cloth to lightly wipe the surface. Let the surface dry naturally. (Do not use rapid drying method to dry the surface.)

Steps: Please follow the above method to wipe the following positions.

1. Pillow 2. Back cushion 3. Leather cover of backrest 4. Leather cover of seat cushion 5. Leather cover of footrest 6. Hand parts 7. Side Panel

Cleaning of armrest and back cover

1. Soak soft cloth in diluted neutral cleanser, and then wring out the cloth.
2. Use the wrung cloth to wipe off the dirt on the equipment.
3. Use clean dry cloth to wipe the equipment.

ⓘ Caution

- Keep the pets away from the chair, their hair may get into the chair and result in mechanical failure.
- Never use wet cloth to clean the chair. May result in mechanical failure

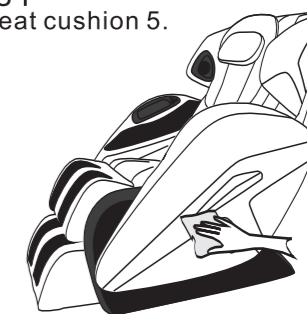

Maintenance and Storage

Routine Maintenance

1. When there is dirt on the equipment, please use cloth soaked with neutral cleanser to wipe the dirty position.
2. Restore the chair armrest and footrest after use.
3. Carefully handle the footrest. Do not press, sit on or step on the footrest.

Storage method

Please keep the equipment in the following conditions:

Ambient temperature: 0°C-40°C

Humidity: (non-condensing) 30% RH~85%RH

Do not store it in a place with high temperature, humidity, or under direct sunshine, or with corrosive gas.

Storage Place

Clean the equipment first. Place it in a dry and dirt-free place. Do not use the equipment in a dirty, oil, humid environment or environment with smoke.

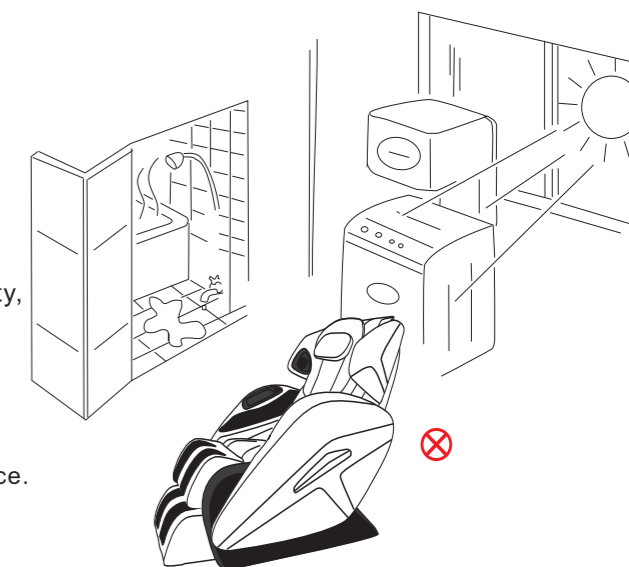

Preparations before Use

1. Where to place it

- Do not keep the chair in a place where humidity is very high like a bathroom.
- Do not keep the chair in a place where it will be exposed to direct sunlight for an extended period of time, or in a place near a heater or radiator where the temperature is very high.
- Lay a carpet or chair mat on the set up place, which can prevent any damage to floor and muffles the noise during massage.
- Do not use in areas of high debris or dust content.
- Keep fire sources such as cigarettes and ashtrays away from the chair.

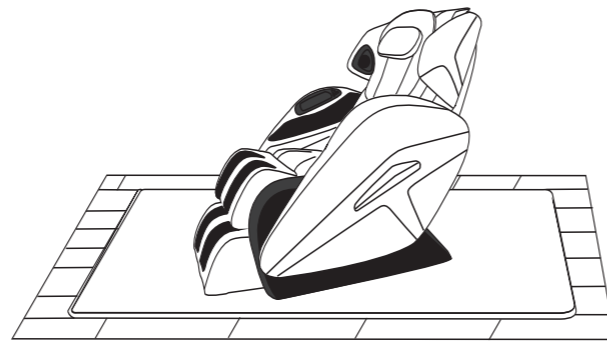

2. Ensure there is sufficient space to allow the massage chair to recline

- A. In order to avoid the backrest touching the walls or other objects when reclined, please set the chair around 4cm away from the back.
- B. Please make sure that no person, pets or any other obstacles is behind the massage chair.

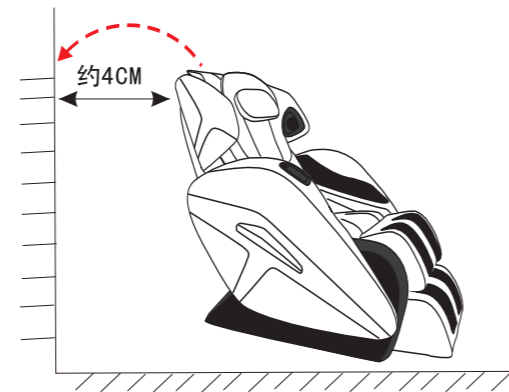

3. How to turn on the power supply

- A. Plug the power cord into the socket.
- ※Before plugging, please be sure to turn the power switch to the "OFF" position.

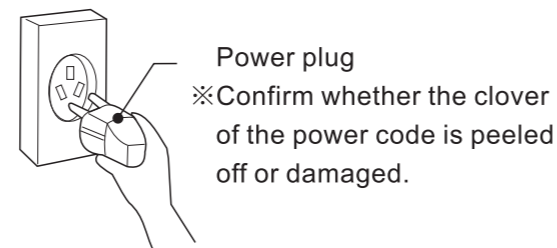

Operating Instructions of Remote Control

ON/OFF KEY
Press the button to turn on the chair and enter the ready mode; press again to turn off the chair and the massage chair will return to the starting position automatically.

Unique programs queuing design
According to personal favorites, you can enjoy 2 programs massage continuously.

Footrest ascending key

Footrest descending key

Fully automatic massage programs
Six fully auto massage programs can be started once you press each single button which massage 15 minutes.

Backrest ascending key

Backrest descending key

Manual function
Each function can be selected separately or combined with other manual massage functions.



Time illuminator
After one auto program 15minutes finished, the blue light will be off, it fade gradually with time passes. The illuminator will turn blue when you choose another program or re-start the machine.

1. Operating instructions of automatic massage buttons

A program of cradle feeling for whole body.

Whole body relaxation massage.

A program which the massage technique is very soft and favorable for those who are exhausted or need a rest.

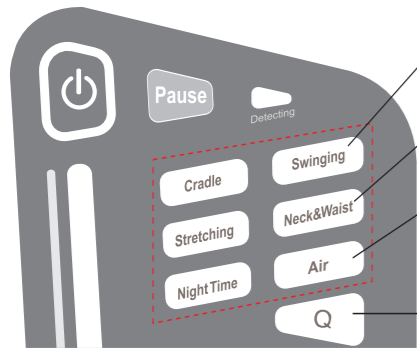
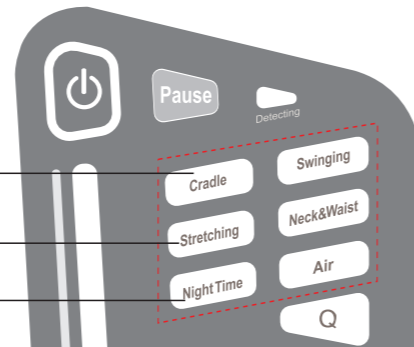

Swing function for hips and waist.

A program aimed for neck and waist which start all-round massage.

Air massage program for whole body.

During auto massage programs, press one program, then press Q button, and then press anyone of the left five auto programs, the second chosen program will be stored and its button shining, the chair will enter into the second program after the first program finished automatically, therefore you can enjoy 30minutes massage continuously in one time. (Attention, Q function can only store one auto program)

2. Operating instructions of manual ascending and descending function buttons

This button is for footrest ascending. Press and hold it to start ascending, meanwhile, the backrest remain still. Release it to stop.

This button is for footrest descending. Press and hold it to start descending, meanwhile, the backrest remain still. Release it to stop.

This button is for adjusting air cushion strength. Blue indicator means low level, purple indicator means medium level and red indicator means high level.

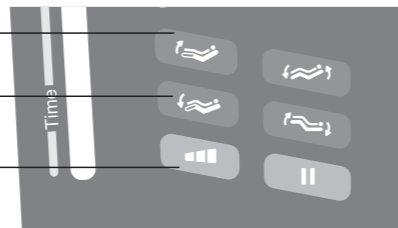

This button is for backrest ascending. Press and hold it to start ascending, and meanwhile the footrest descending. Release it to stop.

This button is for backrest descending. Press and hold it to start descending, and meanwhile the footrest ascending. Release it to stop.

Pause the air massage in 5 seconds.

Installation for Back Cushion and Head Cushion

Install the back cushion with zipper on the backrest and install the pillow onto the back cushion with Velcro.

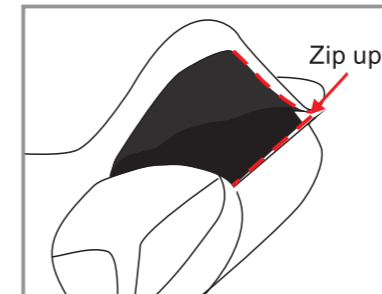

Drawing after installation

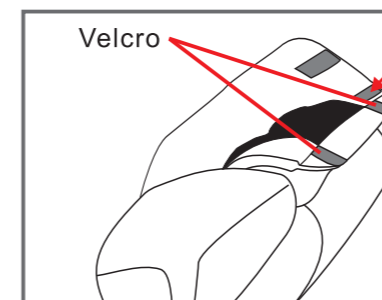

Stick the Velcro

Drawing after installation

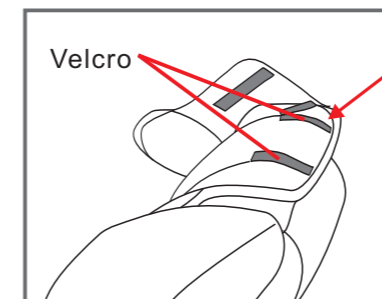
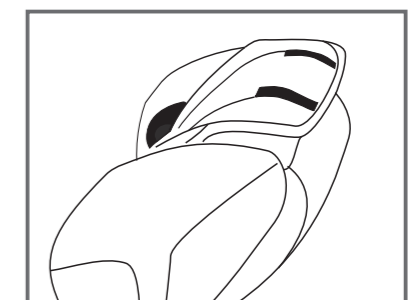

Stick the Velcro

Drawing after installation

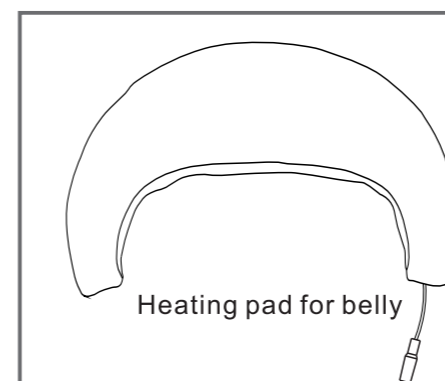
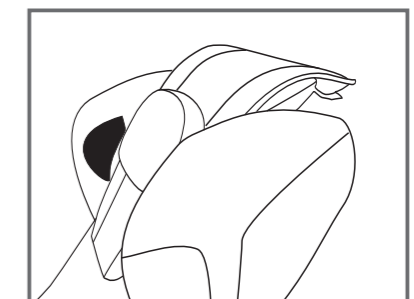

During using, first insert well the heating plug, then press manual button of "heating" to start heating.

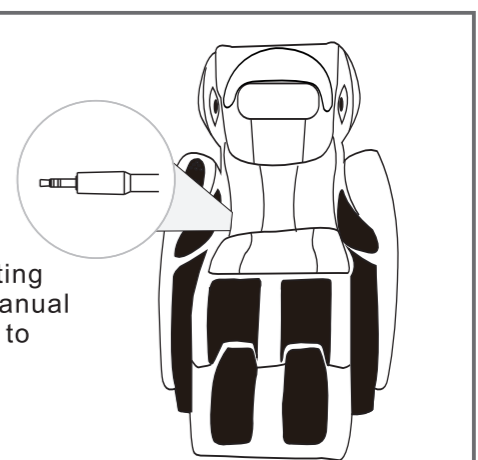

- Please turn the pillow backward during massage.
- In case of very strong massage, use it after installation of pillow.
- In case that it's not used for massage, it can be used as sofa after installation of back cushion and pillow.

二、Connect armrest air tubes and control cables

1. Connect the 2 air tubes marked with A, L of backrest with the air tubes of left and right armrest letter by letter, and then connect well the LED light cables according to different plug color and cable type, then arrange well the cloth cover. (Attention: The left light circuit board is main board, where, in installation, should connect well both the power cable for main light circuit board and connecting cable for both light circuit boards. The right light circuit board is secondary board where can just connect well the connecting cable for both light circuit boards.)

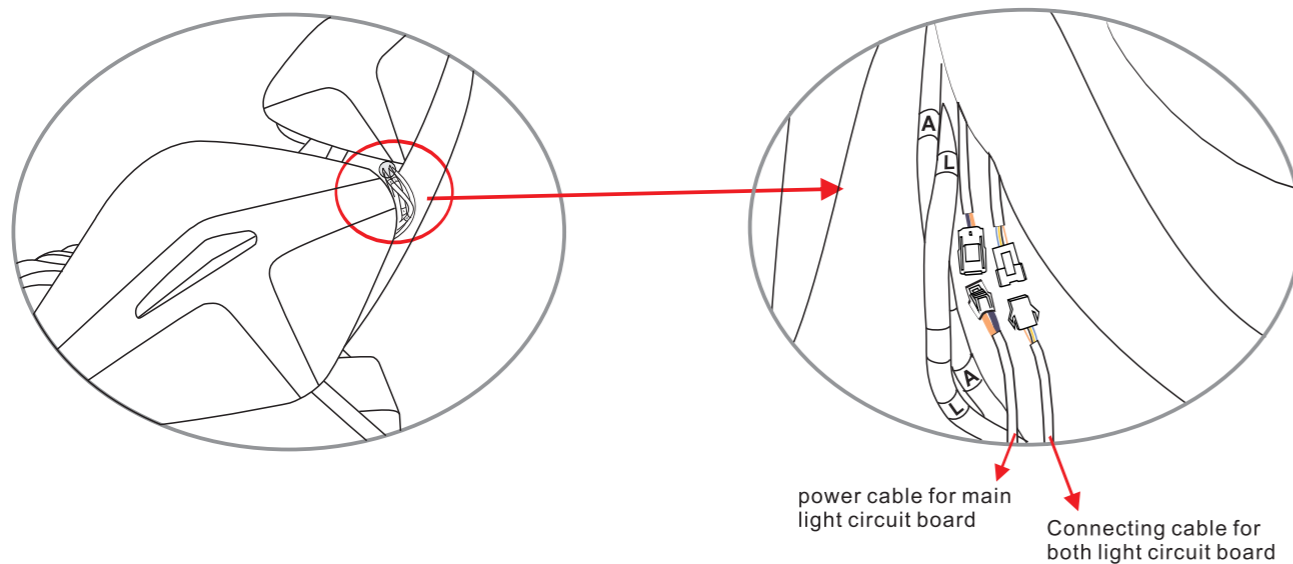

2. Connect well the two control cables from right armrest to underframe accordingly.

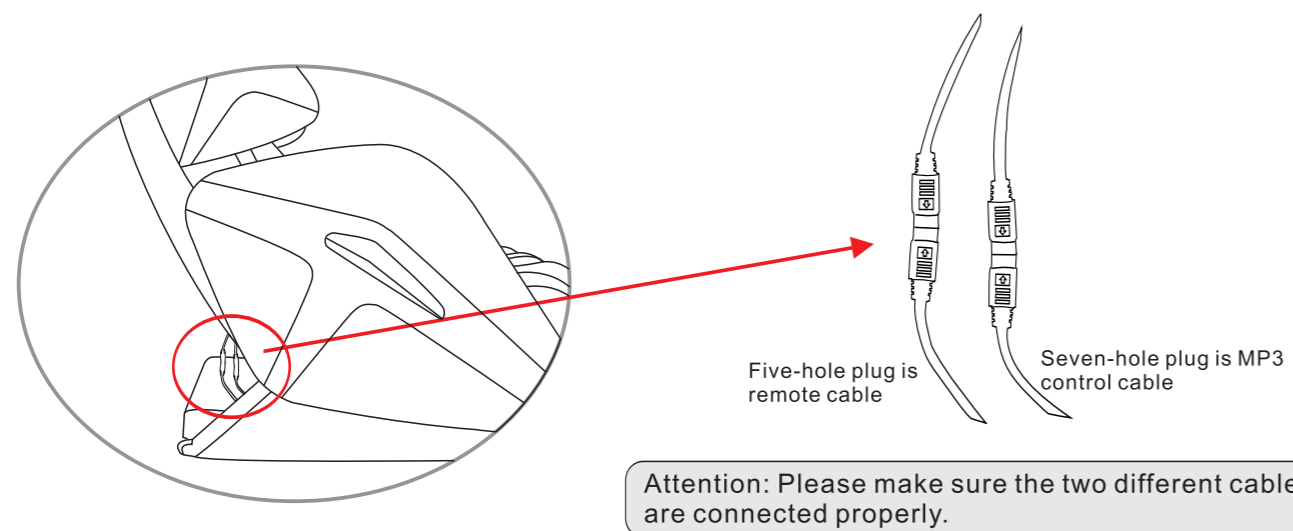

3. Operating instructions of manual function buttons

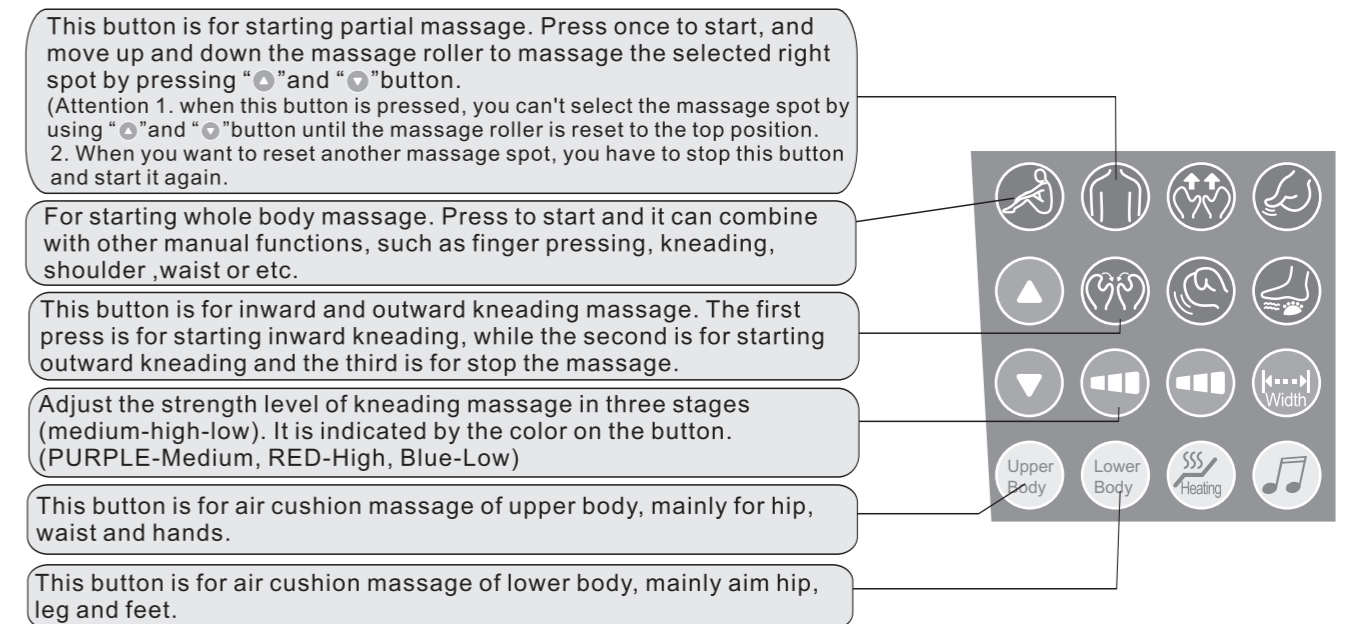
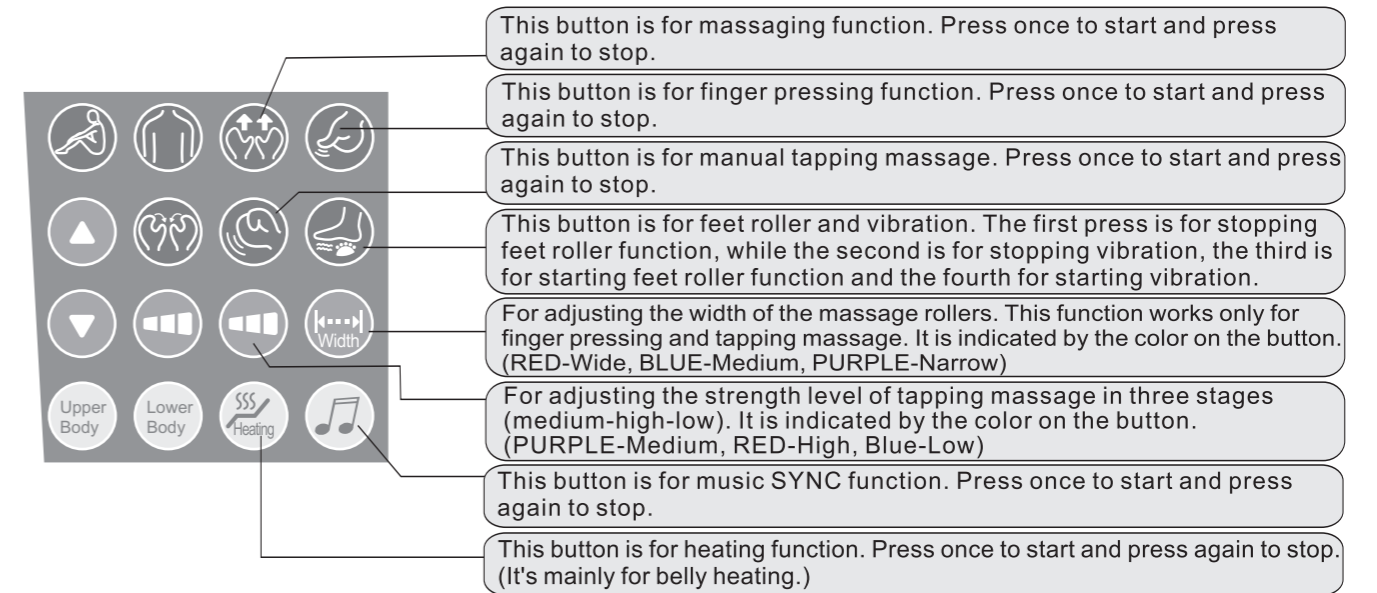

4. Operation instructions for music function

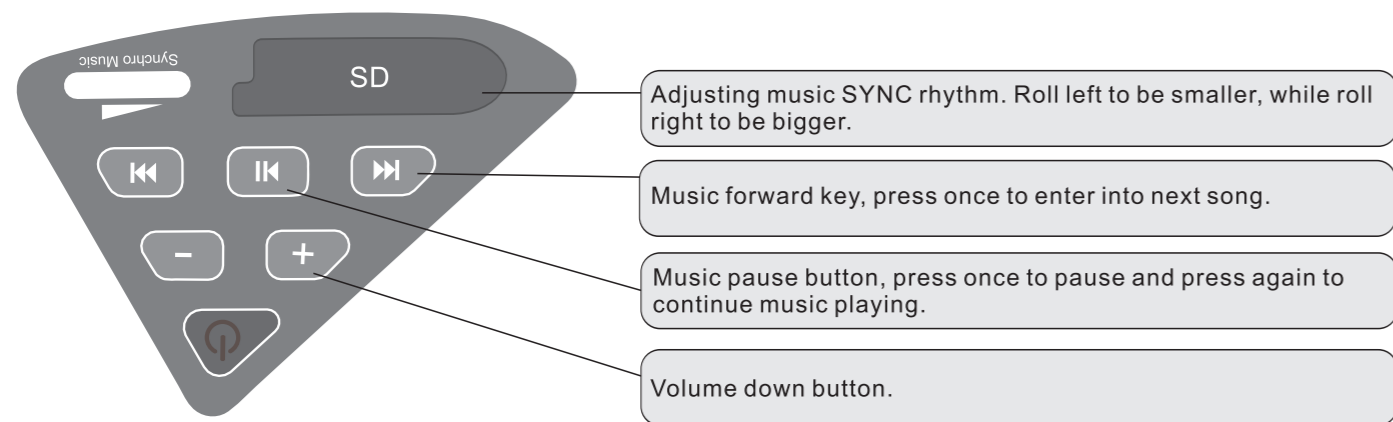
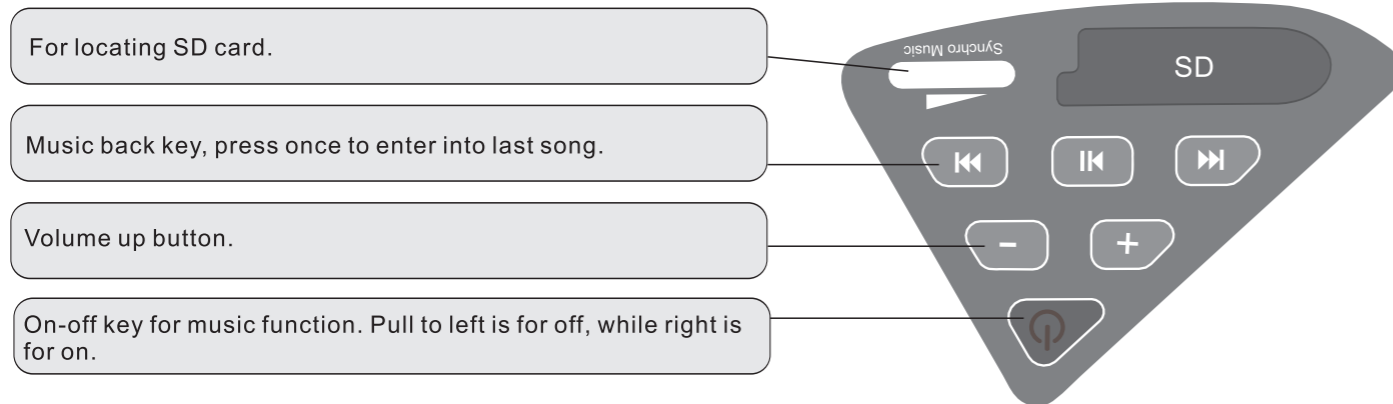

5. Operating instructions for “ROLLER UP” and “ROLLER DOWN” button

- ▲ “ROLLER UP” button, the massage rollers will move up when it is pressed continuously, and release it to stop.
- ▼ “ROLLER DOWN” button, the massage rollers will move down when it is pressed continuously, and release it to stop.

Installation for armrest

一、Assembly steps

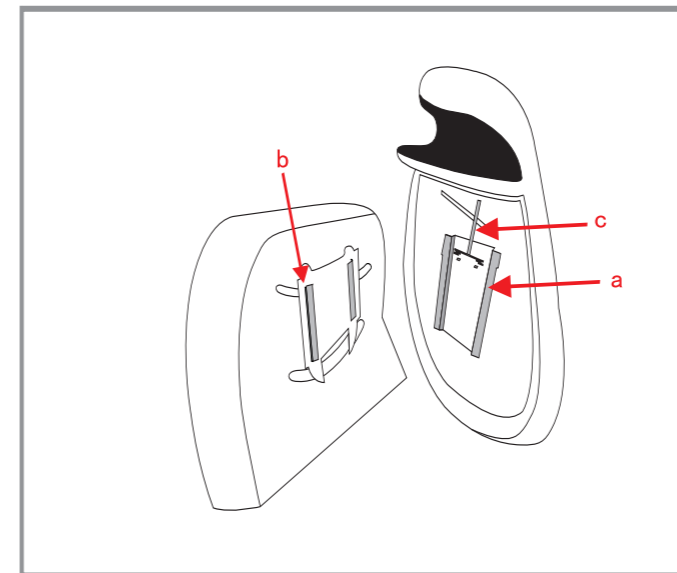

Figure 1

1.As the left figure: a is the fixing clamp position of armrest, b is the fixing sliding slot of armrest, c is the movable rod.

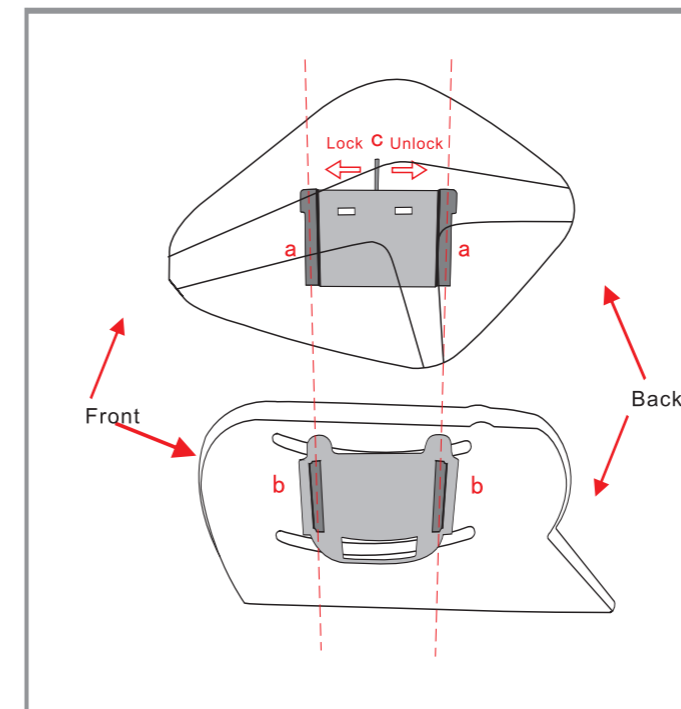
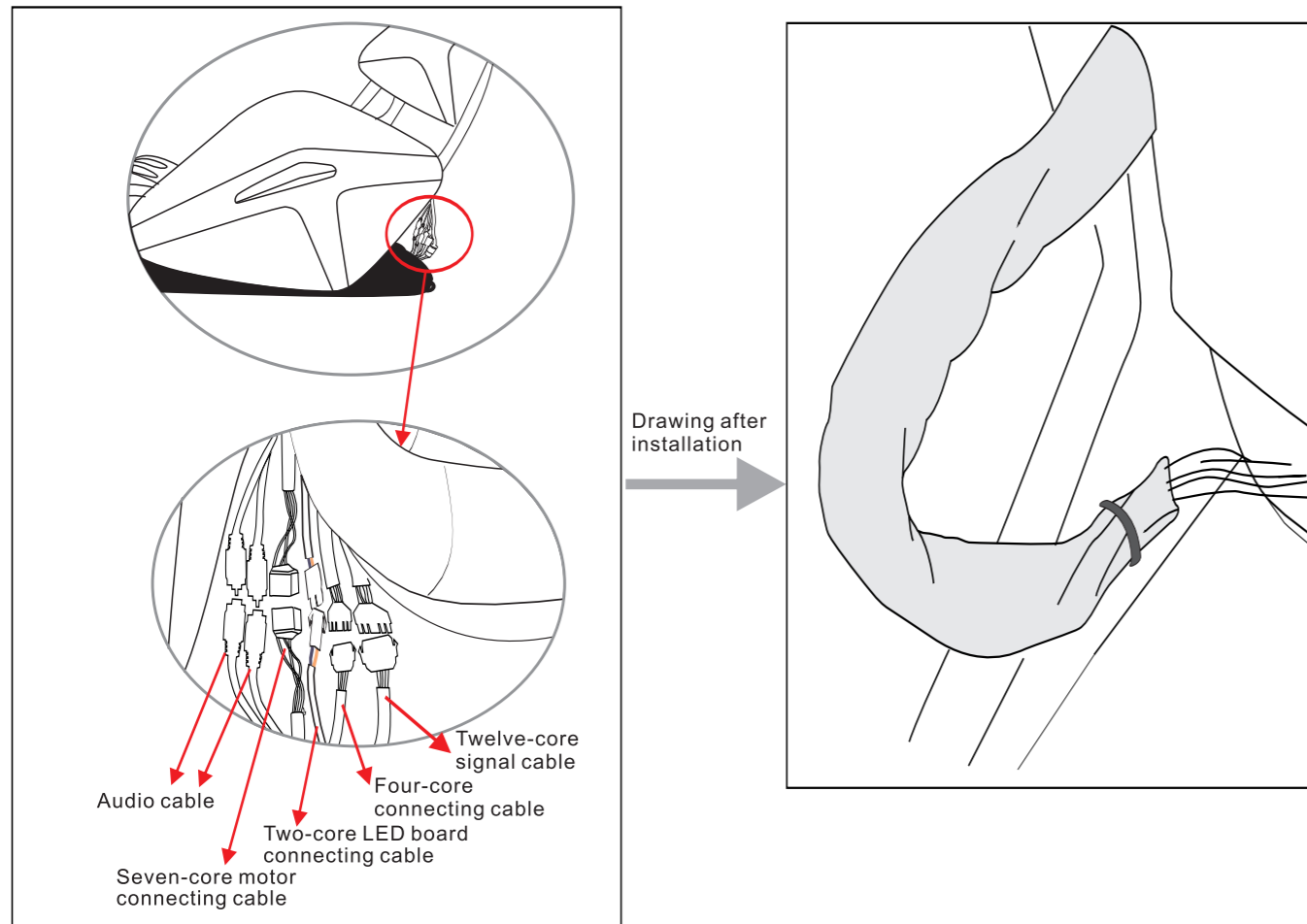

Figure 2

2.As the left figure: Lift the armrest to insert a to b, then using c for locking the armrest. Conversely, if you want to take out the armrest, just unlock c.

Reminder: Please act slowly when lifting the armrest; do not scratch the armrest leather cover.

Step 2: Connect different type of backrest wires color by color, and then arrange well the cloth cover.
(As below figure)



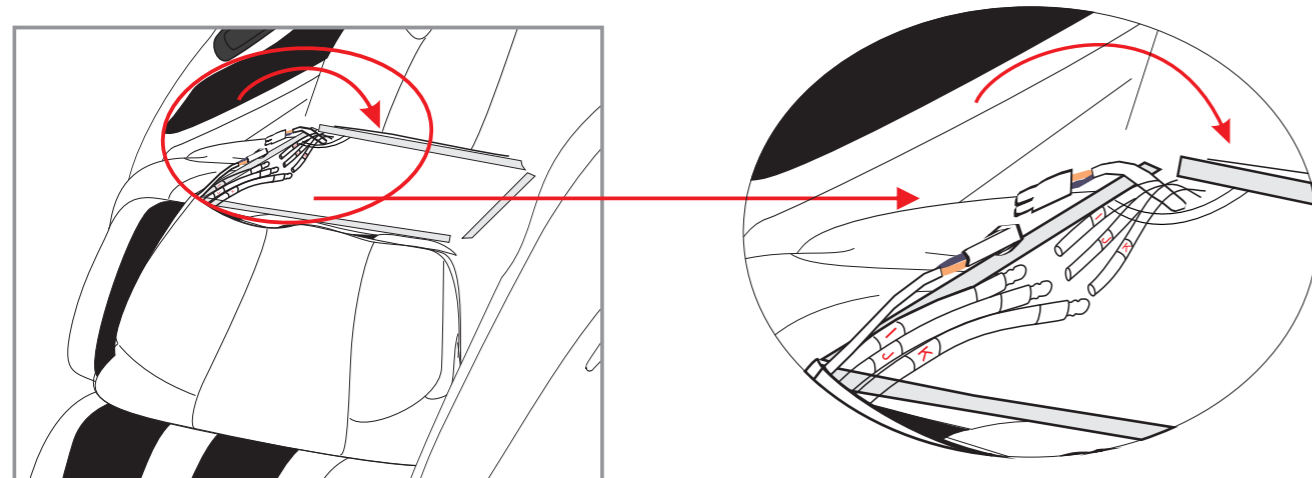

Installation for seat cushion

Connect the 3 air tubes marked with I, J, K with the air tubes on the underframe letter by letter, and then connect well the vibration motor cable, then place the seat cushion in place.





Notices After-Use

A. Reset the chair (the backrest and footrest) to its start position

1. Press the footrest descending button  to put it down. When the front part touches the ground, keep pressing  for another 3 seconds.

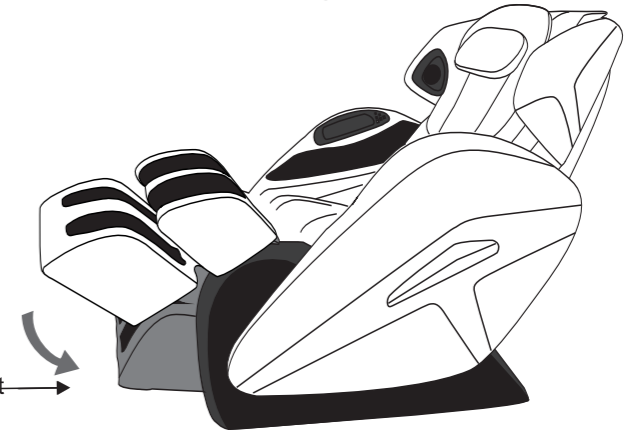
The start position of the footrest



2. Press the backrest ascending key  to raise it up. When the backrest is rising, it's required to keep pressing  for another 3 seconds.

The start position of the backrest.

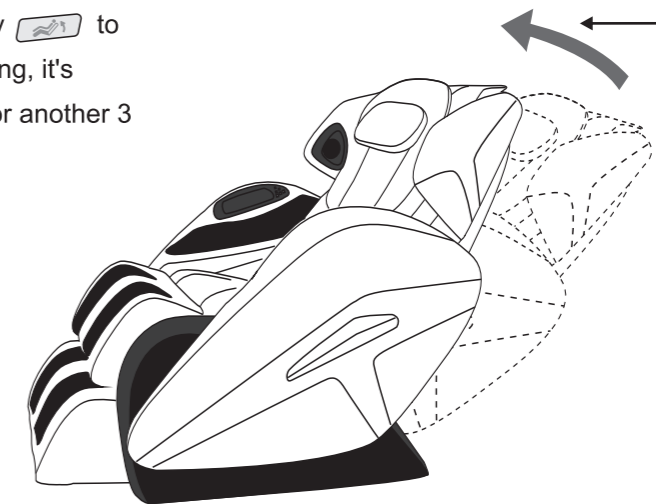

3. Turn the switch button behind the backrest to  OFF position to switch off the power supply.

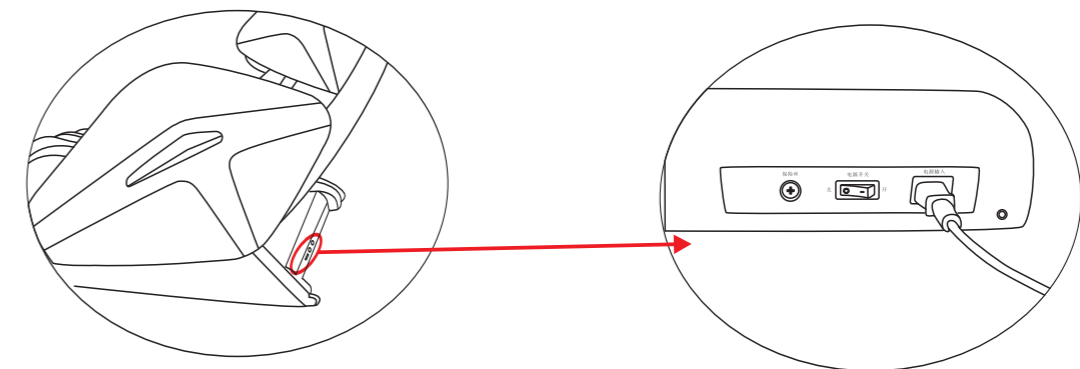

B、 Moving methods

1. To move with caster. Remove the power cable from the socket, then raise the footrest and move the chair forward as shown in below picture.

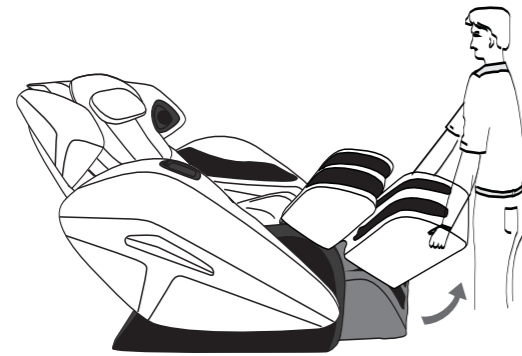

⚠ <Cautions>

1. During moving, please take care not to let the caster get entangled with the power cord and do not step on the power cord.
2. If the floor is easily scratched, do not move the chair by rolling the casters. For moving, the chair should be lifted by two people.
3. Do not move the chair by rolling the casters on cement floor to avoid any damage to the casters.
4. Do not move the chair by lifting, pulling and pushing the armrest to avoid any damage to the armrest.

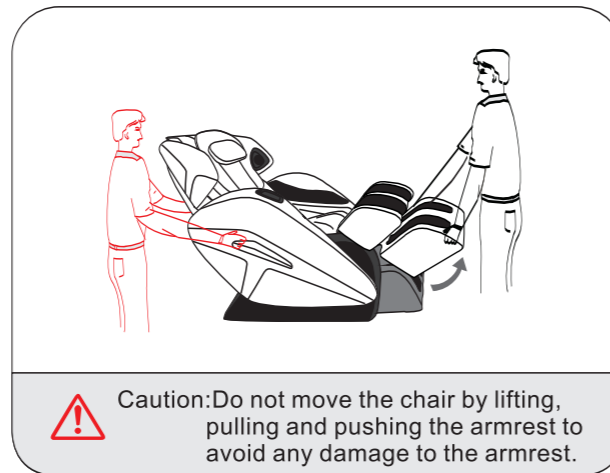

Installation for backrest

一、 Accessories (Accessories are kept in the power cord box.)

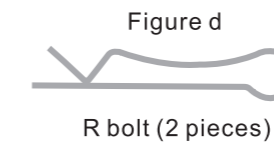

二、 Assembly steps

Step 1: As below pictures instruction: Assemble a (the backrest cannula) into b (underframe cannula), then put d (the R bolt) through c (bolt hole).

