



Thank you for purchasing the TI-Pro Alpine Massage Chair. Before you start using the massage chair, please read this operation manual thoroughly for the correct methods of usage, especially taking note of the section on safety. This manual should be kept on hand for easy reference. It is your guide to a safe and efficient operation.

Contents

Safety Precautions	2
Chair Components	4
Chair Installation	5
Preparation before Using	7
Function Description	9
Chair Specifications	15
Troubleshooting	16
Care & Maintenance	17

Safety Precautions

When using the massage chair, basic precautions should always be followed to reduce the risk of electric shock, burns, fire or injury. Before attempting to use this product please carefully read precautions and follow all the instructions and guidelines.

1. People with the following conditions should consult their physician before using the product:
 - Any with a medical device implanted should NOT use this device unless the doctor prescribes usage. This device has a electrical and magnetic charge.
 - Who suffers from heart disease.
 - Who suffers from bone disease.
 - Who is suffering from bone fragility, especially on the backbone.
 - After surgery.
 - Who is pregnant or menstruating.
 - Who suffers from any type of cancer and/or going through any type of treatment.
 - Who is suffering from osteoporosis.
 - Who has problems with blood circulation.
 - Who is suffering from skin disease or infection.
 - Who is undergoing medical treatment or feels some physical abnormality previously or is being treated now.
 - Who has some abnormality or deformity of limbs or backbone.
 - Who has backbone problems or injuries due to illness or accident.
2. Do not let water enter the product or splashed on the surface of the product.
3. Water contact with electricity is dangerous. Do not leave the product in a humid environment (such as in the bathroom or shower room or swimming pool).
4. Before connecting the product to the power supply, check the product voltage and supply voltage are the same.
5. If the plug, power cord or product itself is damaged, do not use this product.
6. In order to prevent the risk of electric shock, do not open the chair in any manner. A certified technician are only permitted to work on the device and access the components of the chair.

7. Any one with hearing impairment should not use the chair unless supervised by a competent adult.

8. If the product or the power cord is damaged, in order to avoid danger, do not try to repair the product. This must be handled by Seller's full-time specialist / technician, or product quality maintenance guarantee will be void.

9. Children should not use this product. They should be under supervision to ensure the child does not get injured. It is recommended that no children play near the device, especially if the chair is on. Do NOT use this device when pets or kids are near the massage chair.

10. If unusual sound or noise is being heard from the product, turn off the product and immediately disconnect the power connection. Please contact authorized Service center.

11. Do not use the product if cover is damaged or if there is a mechanical or electronic failure. You should contact the authorized Service center.

12. Only place the product in accordance with the instructions in this user manual.

13. Do not use this product in humid conditions and high temperatures or along side hot objects (such as heaters, stoves, fireplace and vents.).

14. Do not apply medical or cosmetic creams on the product or on your body before using this product.

15. Do not shake or drop this product.

16. Do not destroy, bend, stretch, twist or tie the power cord. Damaged power cord can cause fire or electric shock.

17. If the supply cord is damaged, it must be replaced by a special cord or assembly available from the manufacturer or its service agent.

Chair Components

- 1.Backrest
- 2.Armrest
- 3.USB battery charging port
- 4.Side panel
- 5.Headrest cushion
- 6.Backrest cushion
- 7.Seat cushion
- 8.Footrest
- 9.Head to shoulder 4 airbags
- 10.Mid and lower body 14 airbags
- 11.Foot area 18 airbags & 4 foot rollers

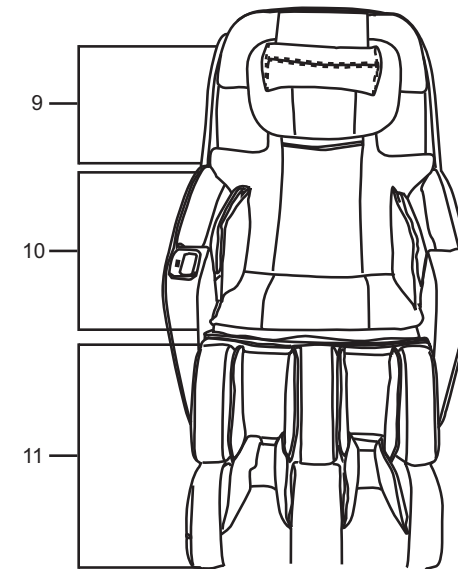
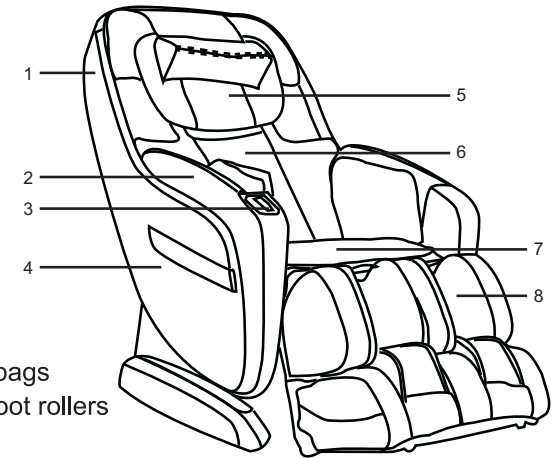

Chair Installation

Step 1:

Connect the wires and air pipes from the footrest and seat part respectively.

Note: Please connect the corresponding wires according to the size of the joint. Please pay attention to the pin and pinhole in alignment.

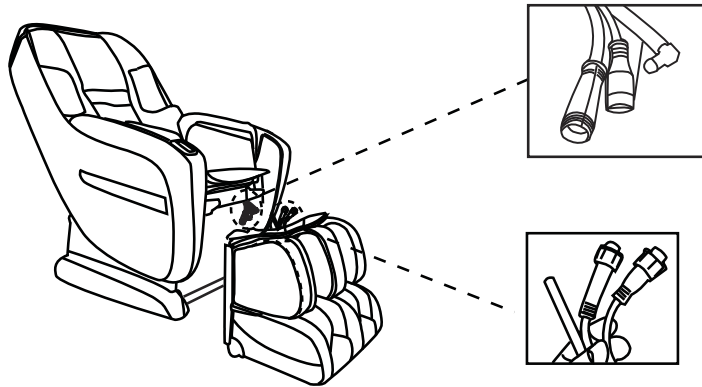

Step 2:

Align the connecting holes from the footrest and seat part, insert a flat head rivet and secure with a split pin as demonstrated.

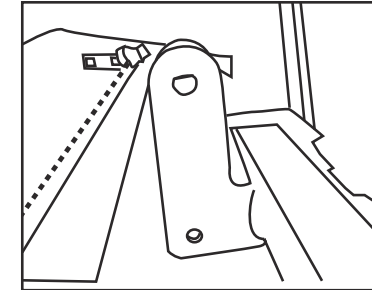
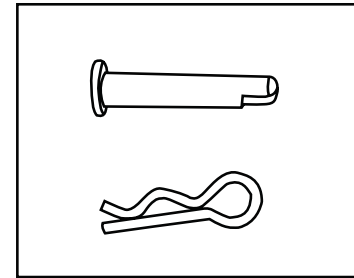
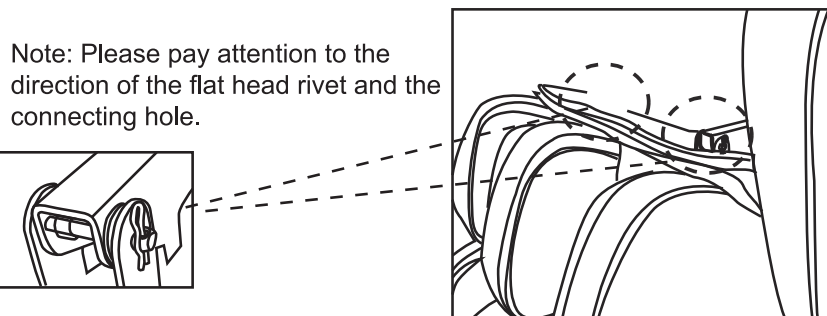

Step 3: Attach the connecting rods of the seat part and footrest with a flat head rivet and secure with a split pin as demonstrated.

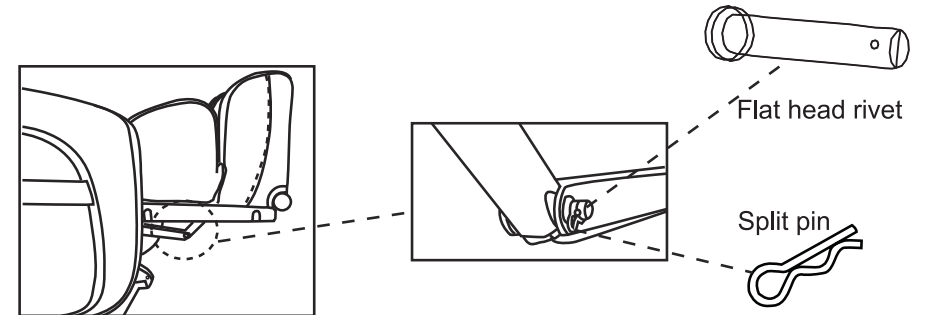

Step 4: Attach the seat cover and footrest cover with the zipper.

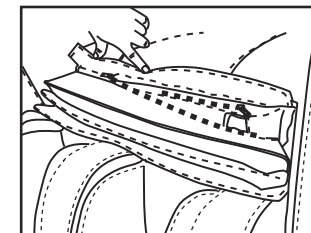

Preparation before Using

1. Placing the chair:

Once the chair has been removed from the packaging, place the chair in the desired location. This chair has been designed with a space saving technology which only requires approximately 4 inches from the backrest to wall when in the upright position. It is also recommended if you have tiled or wood floors to place a rug or mat under the chair to avoid damage to the flooring and also to reduce the noise produced by the air pumps. Before using the chair be sure the chair is in the upright position.

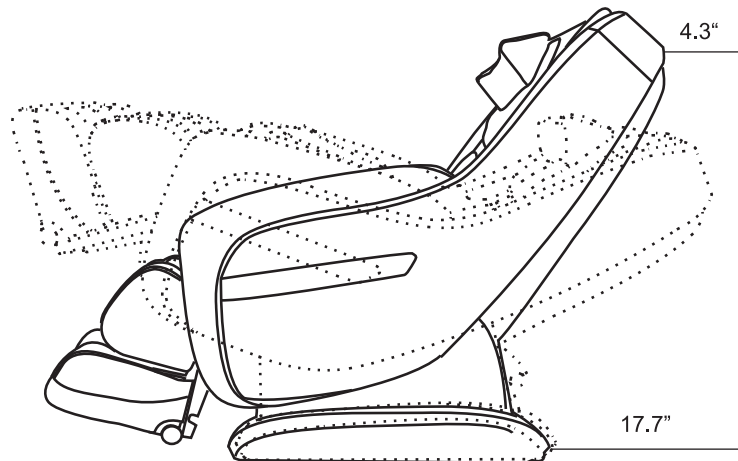

2. Prior to powering the chair:

Before you plug in the chair, be sure the power switch located on the back of the chair at the base is in the "off" position. Then proceed to plug the cord into a SURGE PROTECTOR to prevent from electrical shorts or surges caused by power outages and inclement weather. Once the chair is powered you can now turn the main switch to the "on" position. Comfortably position yourself into the chair and press the "on" the remote and select a desired massage program.

3. Moving the chair:

Before moving the chair be sure the backrest is fully in the upright position with the legrest in the fully down position. This will prevent the motors from being damaged or bent. Then go to the back of the chair and turn the main power switch to the "off" position and unplug from the wall or surge protector. To move the chair there are 2 options, the first is to apply pressure from the top of the backrest and pushing it down towards you so the legs raise up as shown in the diagram on page 7. It is highly recommended that at least 2 able bodies assist in the move to prevent from damage of the flooring, damage to the chair and most importantly to avoid physical injury. During the moving process be sure no pets or young children are nearby. When the chair is tilted back, the weight of the chair will be supported by 2 wheels located at the bottom rear. If you have wood floor, the weight of the chair and the pressure applied to the wheels may cause serious damage to the flooring, leaving indentation and scratches. In this case the 2 option is recommended.

Option 2 is to have 2 or more able bodies to lift the chair completely from the bottom of the chair. Gently place the chair to the ground on the desired location.

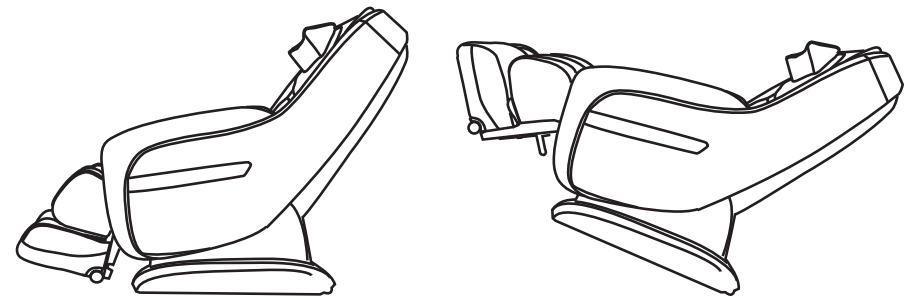

Function Description

1. Power
2. Timer
3. Pause
- 4-9. Auto Programs
- 10-11. Width
- 12-13. Shoulder Position
14. Air Intensity
- 15-16. Air Massage
17. Foot Roller
18. Zero Gravity / Relax Position
- 19-24. Chair Position
25. Sector Massage
- 26-27. Massage Mode
28. Massage Speed
29. Heat
30. Vibration

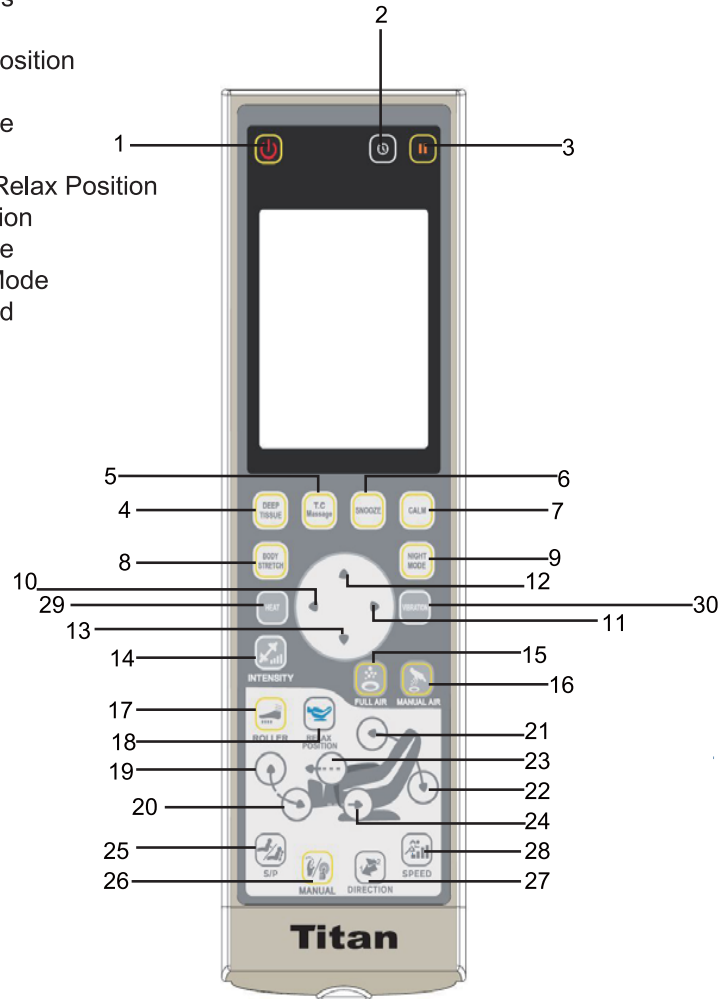

Operation Guide

How to Start

1. Connect the power plug to the power supply.
2. Turn the switch on at the back of the chair.
3. Massage chair will be in idle mode until the functions below are activated:
 - Power
 - Pause
 - Footrest extension
 - Recline (includes backrest and footrest)

Function Description

1. Power

- Starts and stops all functions of the massage chair.
- Press once. Remote control will light up and chair will be in idle mode.
- You can press any massage function buttons to begin your massage session, at a default time of 15 minutes.
- Press again, all functions will stop and massage rollers will return to original position.

2. Timer

- Controls the duration of the massage session.
- The default time for all massage functions is 15 minutes.
- Press each time to change the duration for 20, 25, 30, 05, 10 or 15 minutes.

3. Pause

- All massage functions will stop temporarily.
- Press once and the Pause icon will light up on the LED Display.
- Massage functions and timer will be stopped temporarily.
- Press again to resume the massage session.

Auto Programs

- This function is a full body massage with 6 different massage styles.
- Position of the chair can be manually adjusted.
- Massage session is 15 minutes by default.

4. Deep Tissue

- Engages the full body deep tissue massage. This program focuses on neck, shoulder, waist and hip.

- Relief of a day's work pressure.

5. Traditional Chinese Massage (T.C MASSAGE)

- Engages the T.C Massage Auto Program.

- Massage starts with tapping and air pressure, progressing to in-depth massage targeting the back, arm and foot.

6. Snooze

- Engages the Snooze Auto Program, based on the waist, hips, thighs, and combines air pressure massage.

7. Calm

- Engages the Calm Auto Program.

- This is a gentle massage mode, relieves body pain.

8. Body Stretch

- Engages the Body Stretch Auto Program.

- Stretches the back muscles, hands, hamstrings and thighs and calves.

9. Night Mode

- Engages the Night Mode Auto Program.

- Using different tapping massage mode, massages the full body,

10/11. Width

- Controls the width of the rollers.

- Select a massage function and press to adjust between Narrow, Normal and Wide.

- It can be used to activate the Tapping, Shiatsu and Rolling massage.

12/13. ▲/▼ Position

- To adjust the starting massage position.

- Press the up & down arrow buttons after the computer has completed the body scan. From this you have about 10 sec. to readjust the starting position of the massage heads.

14. Air Intensity

- This button will allow for you to adjust the air pressure intensity in both the manual or preset programs.

15. Full air pressure massage program

- This will initiate all the air bags to inflate sequentially massage the from the hands to the feet.

16. Air pressure massage position

- This button will activate certain air massages to specific regions. When you press this button it will alter the location of the air massage.

17. Foot rollers

- Press once to activate the foot rollers. Press a second time and it will stop.

18. Zero gravity/relax position

- When pressing this button it will take you to the zero gravity reclined position.

19/20. Footrest raise and lower

- This button will allow you to raise or lower the legrest. Press once to start motion and the press again to stop.

21/22. Recline and raising of the backrest

- This button controls the recline and raising of the backrest.

-
- Press again to stop at your preferred angle.

23/24. Footrest Extension

- Control the footrest extension.
- Press once and the footrest will start to extend / shorten.
- Press again to stop the footrest at your preferred position.

25. Sector massage

- Press once to localize the massage to a particular point.
- Press again to shift massage to a particular area of body.
- This will keep the original massage node working on a range of 8cm.
- To resume full back massage, press button again. P6

P7

26. Manual massage modes

- Kneading, Tapping, Swedish, Shiatsu, Kneading and Tapping, Rolling.
 - Press once, to activate Kneading massage of the full back.
 - Each press of button, the massage mode changes in sequence: Tapping>Swedish>Shiatsu>Kneading and Tapping
- >Rolling.

27. Manual mode switching

- Changes the rhythm of manual massage between 1 and 2.
- This will change the manual massage programs.

28. Speed

- Controls the Speed of Tapping, Kneading, Swedish, Shiatsu, Kneading and Tapping massage.
- Select a massage function and press to select between 5 speeds.

29. Heat

- Heat function is set to OFF by default.
- It is applicable during any Automatic Program, Localised Area Program or Manual Program.
- You may also use the heat function on its own

30. Vibration

- The vibration mode can be switched on or off while any of the programs are running.

How to End

- Press the Power button to stop the massage operation.
- Massage rollers will reset automatically.
- The Power button will light up until the massage rollers resume their original position.
- After the Power button light turns off, switch the power button under the chair to "O" position and disconnect the power cord plug.

Usage Tips

1. Massage Angle

"RELAX POSITION" [Button 18] automatically takes you to Zero Gravity position and delivers a more comfortable massage angle. Press once to activate, press again to return to original position.

Note: Zero Gravity position allows the body to enjoy the best position for massage.

2. Massage Intensity

- Adjust the intensity (5 intensity levels) of air pressure massage with [Button 14].
- Adjust the speed of Tapping Massage mode with the Speed [Button 28]. For preference of stronger massage, remove the inner cushion from the backrest cover.

3. Neck Massage

- Remove the small pillow pad and leave just the big pillow pad for a stronger neck massage.
- Removing both big and small pillow pads will allow the most intensive massage.

4. Body Stretching

Before starting the Body Stretch [Button 8], ensure that you are in the correct seating position. Slide your hands properly into the armrest air bags.

5. USB Battery Charging

The USB port can provide temporary charge for mobile phones and tablets.

Note: USB output: 5V, 500mA

Chair Specifications

Description	Specifications
Model NO.	TI-Pro Alpine
Rated Voltage	110-120V~
Rated Frequency	50/60Hz
Rated Power Consumption	200W
Timer	5/10/15/25/30 minutes
Max Time Rate	30 minutes
Upright Dimensions	63.4"x30.7"x47.2" (L x W x H)
Recline Dimensions	78"x30.7"x33.9" (L x W x H)
Net Weight	97 kg
Gross Weight	123 kg
Length of Controller Wire	150cm
Length of Power Supplier Wire	180cm
Environment Temperature	10℃-40℃
Contrasting Humidity level	30-85RH
Storage Temperature	20℃-60℃
Safety Feature	Equipped with overheated and power surge safety protection.

Troubleshooting

This page summarizes the most common problems you could encounter with the product. If you are unable to solve the problem with the information below, contact service center immediately.

If the problem encountered is not listed, please try the following suggestions:

1. Turn off the product and unplug it.
2. Wait for 60 minutes.
3. Plug the product back to the mains and restart.
4. If the problem persists, contact the authorized service center.

Problem	Possible Cause	Suggestion
The product does not work	The product is not plugged in properly.	Ensure the voltage on the product corresponds to the local mains voltage and then plug in again.
After the chair complete a preset program it stopped	The product has just finished its auto timer session and has automatically switched to standby mode.	If you want another session, press the Power button again.
During the massage the chair turned off	You may have used the product continuously for 45 minutes where the over heat protection has been activated.	Unplug the product and let it cool down for 60 minutes before you use it again.
The product does not work	An excessive load has been applied on the product.(The maximum weight capacity is 275lbs.Do not exceed this weight limit.)	Reduce the excessive load and start again.
The product is abnormally warm	The product is likely to be overused.	Unplug the product and let it cool down before using it again.
Noise can be heard from the product	Noise is made by the mechanical parts of the product.	This is normal and does not mean that the product is faulty.

Care & Maintenance

Cleaning

Never use scouring pads, abrasive cleaning agents or aggressive liquids such as petrol or acetone to clean the appliance. When wiping down the chair use non toxic cleaners and be sure the cloth is moist and NOT wet.

Do not immerse to appliance in water.

- 1.Remove the main plug from the wall socket.
- 2.Clean the control panel and cords with a dry cloth.
- 3.Do not use a moist cloth or a cleaning agent.

Storing

- 1.Disconnect the product from the power source after use.
- 2.Keep the massage chair away from direct sunlight, high temperature or high humidity.
- 3.Do not put heavy objects on the product.

If the outer cover is torn or the mechanism is damaged, stop using the appliance and get advice from the service center.

If you have any questions with your massage chair, please do not hesitate to contact the service center.